

COMAR Condensatori



QSR6

USER MANUAL

Index

1	Instruction	p.22	4.2	Key functions	p.32
1.1	Introduction	p.22	4.3	Automatic	p.33
1.2	Operator safety	p.23	4.4	Manual	p.34
1.3	Instructions for proper installation	p.23	4.5	Manual insertion of the banks	p.35
1.4	Cleaning	p.23	4.6	Alarms	p.36
1.5	Warranty	p.24	4.7	Alarm memory	p.37
2	General	p.24	5	Set-up	p.38
2.1	Unit description	p.24	5.1	C/K setting	p.38
2.2	Mechanical fixing	p.24	5.2	P.F. setting	p.39
2.3	Working situation	p.25	6	Working troubles and solution	p.40
2.4	Power of controlled banks	p.25			
2.5	Number of steps	p.25			
3	Technical features	p.26			
3.1	General features	p.26			
3.2	Reference standard	p.27			
3.3	Mechanical dimensions	p.28			
3.4	Pinout diagram	p.29			
3.5	How to choose the C.T.	p.30			
4	Functions	p.32			
4.1	Powering on	p.32			

1 Instruction

1.1 Introduction

Before connecting the regulator to the mains, read the instructions in this handbook, they provide important indications about the safety, use and maintenance. Take carefully this handbook for any information.

This regulator has been manufactured and tested in accordance with international standard, it leaves the factory in perfect safety conditions. In order to maintain these condition and to ensure safe operation, the user must comply with the instructions and remarks given in this manual. After removing the packaging check that the regulator has not been damaged during transport. In case of doubt, do not attempt to fix or use the regulator. If the equipment has fallen down or has been violently shaken during transport, it could suffer internal damages which may be dangerous.

After checking that regulator cannot be safely used, it must be placed out of order and not used before checking of experienced personnel. Causes that bring to put the regulator out of order are the presence of external damages, missed functioning, unproper stocking or transport conditions. Technical Assistance on the regulator must be performed exclusively by COMAR personnel.

1.2 Operator safety

Before to perform any maintenance, the regulator must be disconnected from any power supply source, wait 5 minutes before start any action. During maintenance it is necessary to follow standard safety procedures. Do not touch any printed circuit board for any reason.

This regulator will be assigned only to the use for which it has been specifically made. Each other use has to be considered improper and therefore dangerous.

1.3 Instruction for proper installation

Before connect the equipment, check the data plate: this has to be in conformity with the electrical network (the plate is located on the back of the P.F. Regulator). The regulator is not provided with protection fuse on the power supply, it has to be protected externally by the user. Being the regulator designed for permanent operation (CEI EN 61010-1), the supply have to be interrupted by automatic switch, which has to be placed close the regulator for easy intervention.

For the correct functioning of the equipment, the limit of voltage, current and temperature, imposed by the CEI and IEC standard must never be exceeded. The equipment has to be protected from atmospheric conditions.

1.4 Cleaning

After disconnecting the instrument from the power supply, clean the external surface of the plastic box using a soft cloth dipped in water only. Never use abrasive or solvent. Never wet the connection terminals.

1.5 Warranty

Comar Condensatori S.p.A. guarantees its own products for twelve months from purchase date.

The warranty covers the faults of materials and manufacture and it has to be understood for goods ex-works. Before the equipment works, all instructions, present on this handbook, have to be meticulously followed. Breakdowns caused from improper use and/or not conformity to enclosed instructions and faults caused from tampering by unqualified technicians aren't covered.

The misuse of any of the previous points will erode the right of warranty.

2 General

2.1 Unit description

QSR is an automatic microprocessor regulator which operates the switching on and off of the capacitors steps which are necessary to reach and to maintain the required power factor value. The QSR operate an RMS measure which allows correct operation and display even in presence of harmonics. The central microprocessor unit controls all settings and parameters.

2.2 Mechanical fixing

The regulator should be mounted in a cutout (drilling template 92x92mm.) using the special fixings supplied.

2.3 Warning situation

The regulator works according to binary logic sequence; the switching on and off of capacitors banks always start from the first bank.

2.4 Power of controlled banks

For correct operation of the automatic bank, the power ratio per bank should be:

- | | | |
|----|--------------------------------------|-------------------|
| a. | equal to each other | (1-1-1-1-1-1-1-1) |
| b. | double of the previous bank | (1-2-4-8-16-32) |
| c. | equal or double of the previous bank | (1-1-2-2-4-4) |

2.5 Number of steps

Is determined by the power combination which has been used on single capacitors bank:

- Examples:
- | | |
|---------------------------------------|---------------|
| 6 banks in the sequence 1-1-1-1-1-1 | make 6 steps |
| 6 banks in the sequence 1-1-2-4-4-4 | make 16 steps |
| 6 banks in the sequence 1-2-4-8-16-32 | make 63 steps |

Note. A too high number of steps as a too high power of first step , produce an high number of switching operation that reduce the life of the equipment. When the first step is too high in power hunting may occur which again would produce excessive wear and reduced life of the components.

Normally 8-16 regulating steps is the best solution to adopt

3 Technical features

3.1 General features

Rated supply voltage	Multivoltage 380÷415V a.c. \pm 10% 400V -10% / +5% continuous operation
Rated consumption	3 VA
Rated supply current	By means of CT secondary side 5A max., 1 st class - 5VA (I _{min.} = 500mA)
Current circuit consumption	2VA
Rated frequency	50Hz or 60Hz autose
Controlled banks	6
Output relays	5A 250 Va.c. resistive load
Max current relays common	5A at 40°C resistive load
Switching steps delay	25" (5" on request)
Alarm delay	10"÷ 1"
P.F. setting	0,90 lag ÷ 0,90 lead
Operating range	Power Factor 0,20 ÷ 1,00 lag / lead
Digital monitoring	Alphanumeric 2x16 characters LCD display
Measurement monitoring	P.F. 0,20÷1,00 lag / lead
Accuracy	On the P.F. regulation range \pm 2 f.s. at +25°C and 2,5A.

Temperature accuracy	+/- 10%
Connection	With terminal fixing screws, cable of 2,5 mm ² c.s.a.
Mechanical dimensions	96x96 mm FRONT (according to DIN43700) 60mm DEPTH
Cut out dimension	92x92 mm (tolerance -0mm /+ 1mm).
Mechanical fixing	With the special accessories supplied included
Plastic case	Insulating self-extinguishing material
Weight	0,5 Kg
Protection degree	IP 54 front panel - IP20 terminal board
Working temperature	0°C to + 50°C
Storage temperature	-20°C to +60°C
Relative humidity	Max. 90% at 20°C noncondensing
Type of service	Indoor service, no dusty condition. Do not place directly under sun light.

3.2 Reference standard

Safety	IEC 1010 440V CAT III
EMC	EN50082-1, EN50082-2, EN50011, EN55022
Protection degree	CEI-EN 605.29

3.3 Mechanical dimensions

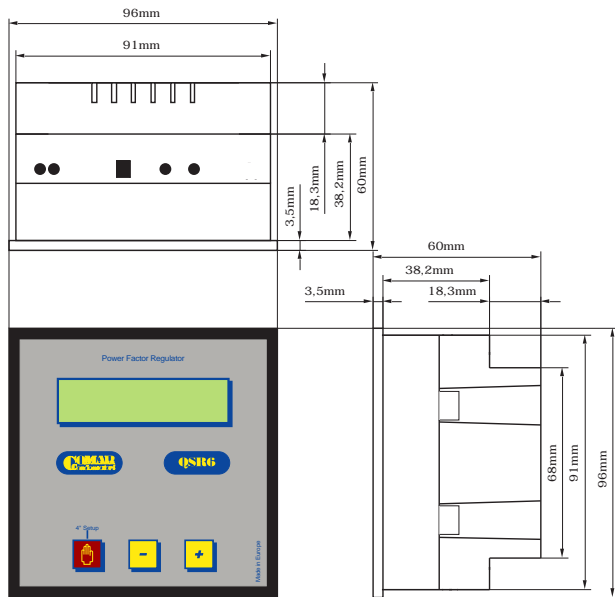

ENGLISH

3.4 Pinout diagram

Carichi
Loads
Charges
Verbraucher
Cargas

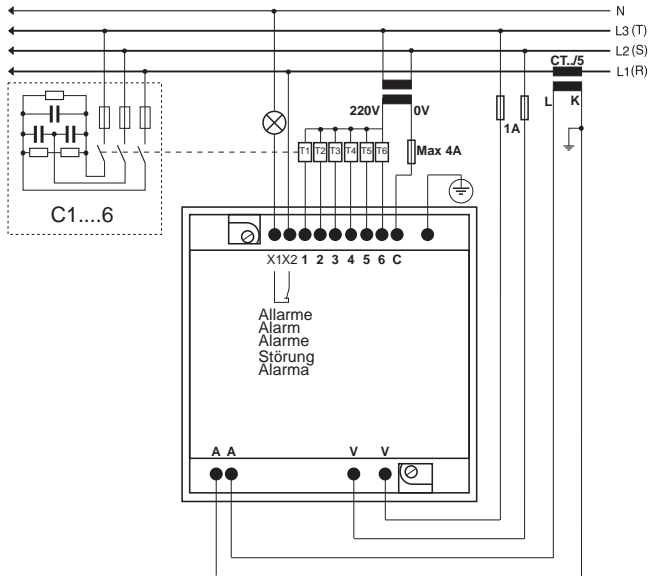

ENGLISH

3.5 How to choose the CURRENT TRANSFORMER (C.T.)

Use a Current Transformer (C.T.) with 5A at secondary circuit and primary equal or slightly higher than the maximum absorbed by the loads. The C.T. must be chosen in such a way to obtain a good current signal in the secondary circuit. Current values between 0.5 and 5Amps are suitable to obtain good working conditions of the regulator.

The C.T. must be good quality (first class) and with power equal or higher to 5VA. If the C.T. has been mounted far from the equipment, it needs to add the normal demanded the power consumed from the cables of connection (normaly 0.2VA per meter of bifilar lines with 2.5mm² section) and the power dissipated by others possible tools connected in the circuit. The equations, used to calculate the real losses, are the sequents:

$$R = 2 \times \rho \times L/S \quad (\Omega) \quad \text{Total resistance of amperometric circuit}$$

$$P = (R + 0.08) \times I^2 \quad (\text{VA}) \quad \text{Losses of amperometric circuit}$$

' ρ ' is the electrical resistivity (0.018 for the copper)

' L ' is the length of amperometric circuit (mt)

' S ' is the across section of cables at the secondary of TA

' I ' is I_{max.} at the secondary of C.T.

'0.08' are the internal resistance of P.F. regulator

When single-phase inductive loads are connected (unbalanced three-phase system), place C.T. on the phase where Power Factor is lower and/or where higher current value is absorbed.

The cables at the secondary of C.T. have to be of 2,5mm² section.

The C.T. connection must not to be protected with fuses or interrupted by switch.

The C.T. has to be connected to the line, upstream the load and the P.F. Regulator: the C.T., can then measure the current demanded by the load, inductive and capacitive. Possible capacitors for fixed P.F. Regulation will be mounted downstream of the C.T., as they aren't used and dimensioned for the P.F. Regulation of transformers that feed the load. It's important to check that the phase, where the C.T. is connected, is the same that will be connected to terminals of the main switch, inside the equipment, signed with the letter "L1".

Before doing any work on the C.T. circuit, be sure that the C.T. is short-circuited, otherwise dangerous voltages can rise, add bringing to breakdown the C.T.

P.F. correcting two or more lines (transformers in parallel), you need to use two or more C.T (.../5) of which the secondary circuits will be supplied a add transformer with 5Amps at secondary: connect the current transformers at the same phase.

If two or more C.T. 's are used with an additional transformer, the value of the primary current is the sum of each C.T. Example: n°3 C.T. 's 500/5 = n°1 C.T. 1500/5.

Connecting two or more cables (for load and P.F.Regulator) on the same terminal - phase "L1" - from the general main switch, It needs to pass through the hole of the C.T. all the derived cables.

Note. QSR regulators are able to detect automatically the current phasing of the CT. It is not necessary to ensure correct polarity connections as with other Power Factor Regulators.

4 Functions

4.1 Powering on

When power is switched on, an internal self test routine has been performed. The display shows the installed s/w release.



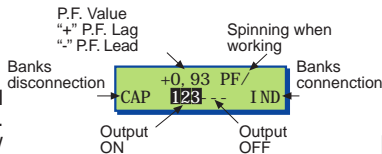

After start-up process, the regulator is working in "Automatic" operation.



4.2 Key function

The key  enable change from "Automatic" to "Manual" (light is on). When pressed for 4 seconds it enable to enter the set-up page and confirm setting

Keys   used in "Manual" enable switch-on and off the output. Used in "SET-UP" enable setting of the value. Used in "Automatic" enable visualization and reset of "Alarm memory".

4.3 Automatic

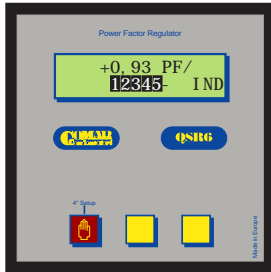

Fig. 1

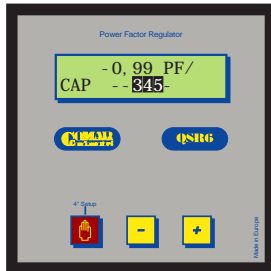

Fig. 2

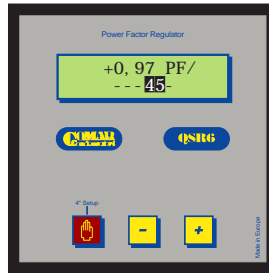

Fig. 3

Fig.1: inductive loads connected (motors, transformers, decharge lamps, etc.).

“IND” indication on and regulator that inserts the required outputs.

Fig. 2: capacitive loads connected. “CAP” indication on and regulator that disconnects the exceeding outputs.

Fig. 3: P.F. value setted is achieved when Cap and IND indications are off. Output are not changing.

ENGLISH

4.4 Manual

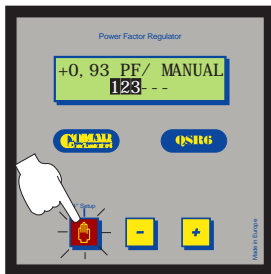

Fig.1 The key is lit (on)

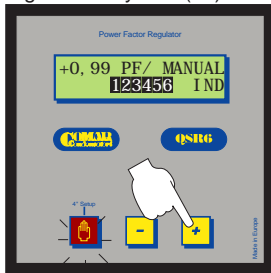

Fig.2 Output insertion (switch on)

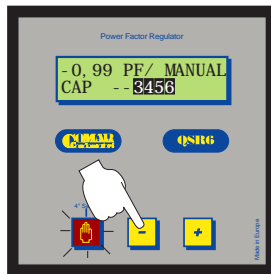

Fig.3 Output switch off

Manual working visualize balanced load (IND and CAP indication off).

Switch on/off are made only after the proper response time (25 seconds standard).

ENGLISH

4.5 Manual insertion of the banks

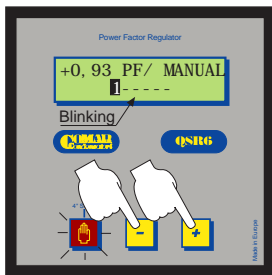
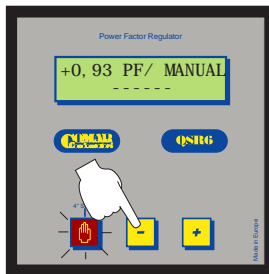
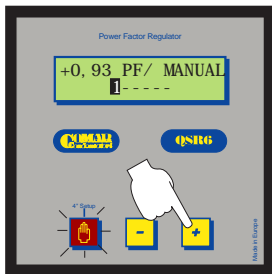











In Automatic operation the “stored” output are always on. The remaining output are working in Automatic, the stored output can be disconnected exclusively when operation shows in fig.3 occurs (key on, key pressed) or switching off the power supply

ENGLISH

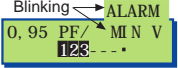
4.6 Alarms

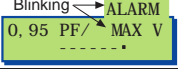
The QSR has a normally closed NC alarm contact (rated 5 A 250 V resistive load). It will be possible to give an external alarm signal. This contact is signed with X1 and X2 in the base of the regulator.

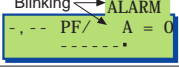
When alarm condition disappears, the regulator will reset itself automatically.

Reference	Condition	Display indications	Alarm relay
No supply voltage	$V = 0$		X1 X2 
Low P.F. value in the network	PF = IND for 15 minuts	Blinking 	X1 X2 
Low voltage	$V < 340\text{Vac RMS}$ for 10 seconds	Blinking → ALARM 	X1 X2  Quick switch off for all outputs
High voltage	$V > 450\text{Vac RMS}$ for 10 seconds	Blinking → ALARM 	X1 X2  Quick switch off for all outputs
Zero Current	$A < 50\text{mA RMS}$ for 10 seconds	Blinking → ALARM 	X1 X2  Quick switch off for all outputs

Reference	Condition	Display indication	Alarm relay
Low current	$A < 350\text{mA RMS}$ for 10 seconds	Blinking → ALARM 0, 35 PF/ MIN A 123- - - .	X1 X2 Inhibit output insertion
Hight current	$A > 5,5\text{A RMS}$ for 10 seconds	Blinking → ALARM 0, 95 PF/ MAX A 123- - - .	X1 X2
Leading P.F. value	$\text{PF} < \pm 0,20$ for 10 seconds	Blinking → ALARM - - - PF/ CAP - - - - - .	X1 X2 Quick switch off for all outputs
Hight temperature	$T^\circ > 50^\circ\text{C}$ for 10 seconds Hysteresis level 5°C	Blinking → ALARM 0, 95 PF/ TEMP - - - - - .	X1 X2 Quick switch off for all outputs
No alarm	Standard operation	0, 95 PF/ 123- - - .	X1 X2

4.7 Alarm memory

To visualize last alarm press

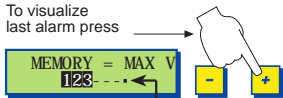

A dot indicates an alarm message stored in memory

To erase memory press at the same time

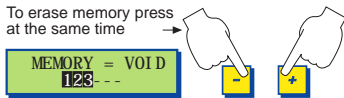

5 Set-up

5.1 C/K setting

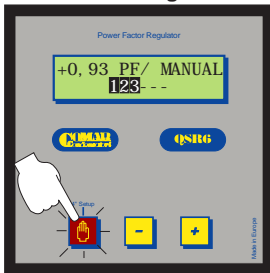

Push 4 seconds for aut. functioning

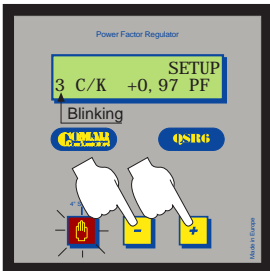

The suggested value to set is given on the table.

Use the  or  buttons to change the selection.

T.A. - C.T.	Power 1 st bank (kvar)							
	5	6	10	12,5	20	25	40	50
30/5	5	5	-	-	-	-	-	-
50/5	3	4	5	-	-	-	-	-
60/5	3	4	5	5	-	-	-	-
80/5	3	3	5	5	-	-	-	-
100/5	3	3	3	4	5	-	-	-
150/5	2	3	3	3	5	5	-	-
200/5	2	2	3	3	3	4	5	-
250/5	2	2	3	3	3	3	5	5
300/5	2	2	2	3	3	3	4	5
400/5	2	2	2	2	3	3	3	4
500/5	1	2	2	2	3	3	3	3
600/5	1	1	2	2	2	3	3	3
800/5	1	1	2	2	2	2	3	3
1000/5	1	1	1	2	2	2	3	3
1200/5	1	1	1	1	2	2	2	3
1500/	1	1	1	1	2	2	2	2
2000/5	1	1	1	1	1	1	2	2
2500/5	1	1	1	1	1	1	2	2
3000/5	1	1	1	1	1	1	2	2
4000/5	1	1	1	1	1	1	1	2

When the CT secondary current signal is lower than 2 amps, the C/K value should be increased by 0,1.

When using the regulator on 220Vac networks the C/K values should be doubled.

"-" means installation of C.T. with primary value too small.

ENGLISH

5.2 P.F. setting

After setting the C/K value

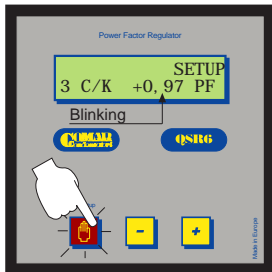

Press the “Manual” key

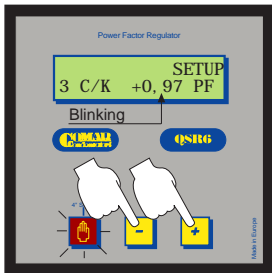

Use the  or  buttons to change the selection. A P.F. of 0,95 is recommended.

By pressing the  button, the C/K and P.F. values which have been selected will be saved and the regulator works in “Automatic” condition.

ENGLISH

6 Working troubles and solution.

TROUBLE	Soluzione
All banks on with a low inductive load on the network	The CT is connected upstream the load but not of capacitors. Connect the CT as shown in the connection diagram (§ 3.4).
Continous switching on and off of first bank (hunting phenomena)	a) The C/K value is not correct. Check in the table "C/K VALUES" for the right value (§ 5.1). b) The power of the first bank is too high for the selected PF requirements. Reduce the first bank power according to paragraphs 2.4 and 2.5. Increase the selected PF value (§ 5.2).
Displayed PF values not correct	CT installed in the wrong phase: connect to phase L1 (§ 3.4).
IND and CAP leds off	a) Possible stand-by condition: at least one capacitor bank on. Check the PF value of the network on the display. b) Possible MANUAL working condition: choose the AUTOMATIC operation.
IND led ON and no insertion of capacitor banks	Minimum current alarm. Current lower than 500mA (see § 4.6).
CAP led is ON without capacitor banks working	CT installed in the wrong phase: connect to phase L1 (see § 3.4).
Blinking display	a) Alarm condition of least one value: see chapter (§ 4.6). b) Check supply voltage is correct.
Display off, regulator not working	a) Check if supply voltage is present. b) Check if supply voltage is equal to the rated voltage of the regulator.
Display on, banks inserted signalling, but capacitors not working	a) Check if supply voltage is equal to the rated voltage of the regulator. b) Check the "0Vac" connection on contactors. c) Check if "220Vac" has been connected on "C" terminal. d) Check contactor functioning.
Displayed "ALARM CAP" on display	a) Possible capacitive load condition. b) CT installed in the wrong phase: connect to phase L1 (§ 4.6). c) P.F. lower than 0,20 IND or CAP.
Displayed "-.-" on display	a) Zero current signal: check the C.T. and its connection and ensure the minimum secondary current level is least 10mAmps (§ 3.4). b) C.T. connected on the supply cable of the PFC equipment. Connect according the connection diagram (§ 3.4).

ENGLISH

IF PROBLEMS PERSIST AFTER ALL ABOVE MENTIONED SOLUTIONS SWITCH OFF THE REGULATOR FOR AT LEAST 20 SECS AND THEN SWITCH ON AGAIN. IF THE PROBLEM IS STILL PRESENT PLEASE CALL OUR TECHNICAL DEPARTMENT.