

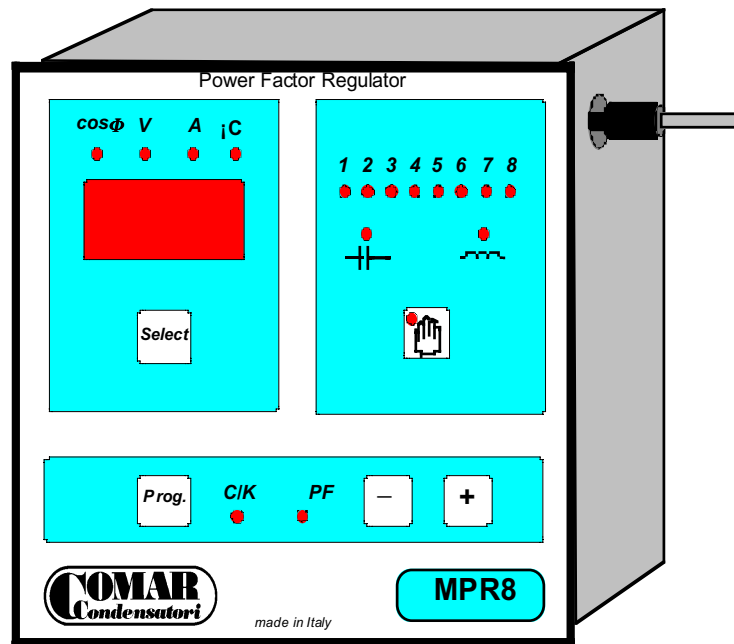

Via del Lavoro, 80 - 40056 CRESPELLANO (Bologna) ITALY - (+39 051/733.383 - Fax. +39 051/733.620
P.O. BOX, 150 - 40011 ANZOLA EMILIA (Bologna) - ITALY



INSTRUCTION MANUAL
ELECTRONIC POWER FACTOR REGULATOR type **MPR**

• **ENGLISH**

1. MAIN FEATURES.....	pag. 10
2. HOW to CHOOSE the CURRENT TRANSFORMER (C.T.).....	pag. 10
3. INSTRUCTION for the USE.....	pag. 11
3.1 ELECTRICAL CONNECTION	
3.2 MECHANICAL FIXING	
3.3 POWER of CONTROLLED BANKS	
3.4 NUMBER of STEPS	
4. WORKING SITUATION.....	pag. 12
5. DIGITAL DISPLAY.....	pag. 12
6. SETTING ON REGULATOR.....	pag. 12
C/K setting	
P.F. setting	pag. 13
6.1 SAVING the SET VALUES	pag. 13
7. ALARMS.....	pag. 14
8. WORKING TROUBLES and SOLUTION.....	pag. 15
9. TECHNICAL DATA.....	pag. 15
10. INSTRUCTIONS, WARRANTY and LIABILITY.....	pag. 16

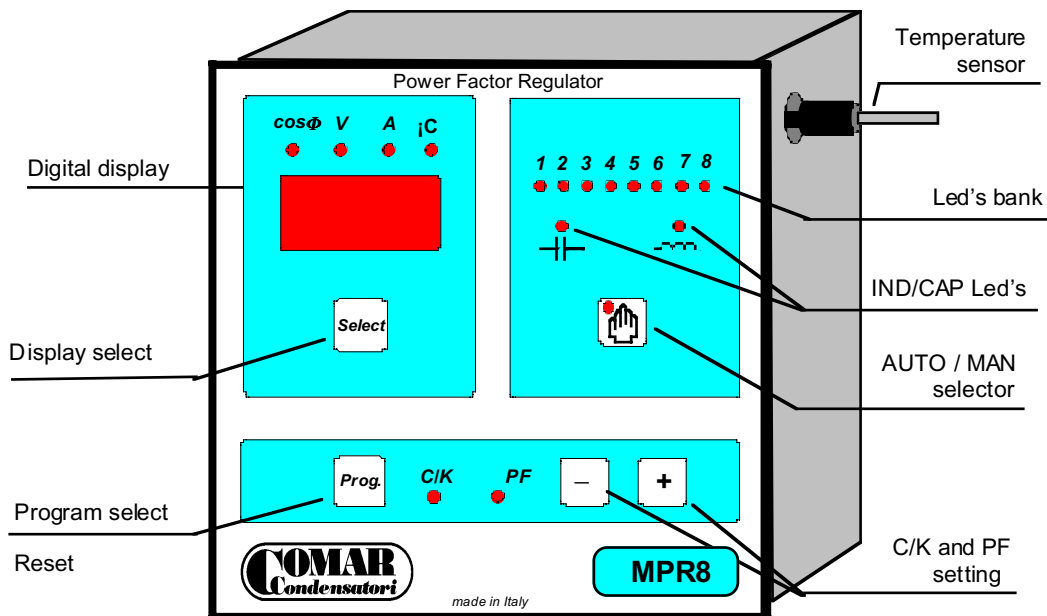

1. MAIN FEATURES

MPR is an automatic microprocessor regulator which constantly controls the phase displacement between current and voltages waves on zero crossover, and operates the switching on and off of the capacitors steps which are necessary to reach and to maintain the required power factor. The MPR is fitted with an input filter which allows correct operation and display even in presence of harmonics. The central microprocessor unit controls all settings and parameters.

2. HOW to CHOOSE the CURRENT TRANSFORMER (C.T.)

- Use a Current Transformer (C.T.) with 5A at secondary circuit and primary equal or slightly higher than the maximum absorbed by the loads. The C.T. must be chosen in such a way to obtain a good current signal in the secondary circuit. Current values between 0.5 and 5Amps are suitable to obtain good working conditions of the regulator.
- The C.T. must be good quality (first class) and with power equal or higher to 5VA. If the C.T. has been mounted far from the equipment, it needs to add the normal demanded the power consumed from the cables of connection (normally 0.2VA per meter of bifilar lines with 2.5mm² section) and the power dissipated by others possible tools connected in the circuit.

The equations, used to calculate the real losses, are the sequent:

$$R = 2 \times \rho \times L / S \quad (\Omega) \quad \text{Total resistance of amperometric circuit}$$

$$P = (R + 0.08) \times I^2 \quad (\text{VA}) \quad \text{Losses of amperometric circuit}$$

ρ is the electrical resistivity (0.018 for the copper)

L is the length of amperometric circuit (m)

S is the across section of cables at the secondary of TA

I is I_{max.} at the secondary of C.T.

0.08 are the internal resistance of P.F. regulator

- When single-phase inductive loads are connected (unbalanced three-phase system), place C.T. on the phase where Power Factor is lower and/or where higher current value is absorbed.
- The cables at the secondary of C.T. have to be of 2,5mm² section.
- The C.T. connection must not to be protected with fuses or interrupted by switch.
- The C.T. has to be connected to the line, upstream the load and the P.F. Regulator: the C.T., can then measure the current demanded by the load, inductive and capacitive. Possible capacitors for fixed P.F.Regulation will be mounted downstream of the C.T., as they aren't used and dimensioned for the P.F. Regulation of transformers that feed the load. It's important to check that the phase, where the C.T. is connected, is the same that will be connected to terminals of the main switch, inside the equipment, signed with the letter R (L1).
- Before doing any work on the C.T. circuit, be sure that the C.T. is short-circuited, otherwise dangerous voltages can rise, add bring to breakdown the C.T.
- P.F. correcting two or more lines (transformers in parallel), you need to use two or more C.T (.../5) of which the secondary circuits will be supplied a add transformer with 5Amps at secondary: connect the current transformers at the same phase. If two or more C.T. s are used with an additional transformer, the value of the primary current is the sum of each C.T. Example: n₁3 C.T. s 500/5 = n₁1 C.T. 1500/5.
- Connecting two or more cables (for load and P.F.Regulator) on the same terminal - phase R (L1) - from the general main switch, it needs to pass through the hole of the C.T. all the derived cables.

Note. MPR regulators are able to detect automatically the current phasing of the CT. It is not necessary to ensure correct polarity connections as with other Power Factor Regulators.

3. INSTRUCTION for the USE

3.1 ELECTRICAL CONNECTION: by means of plug connector with terminal fixing screws for the cable have to be of 2,5mm² section, mounted in the base of the regulator.

Fig. 1
The external connection

- It is very important to ensure correct connection of the CT (in L1 phase upstream of the load and phase shifting capacitors) and the voltage connection (on phases L2 and L3), as shown in the schematic below, in order to ensure a correct measurement of the unit.

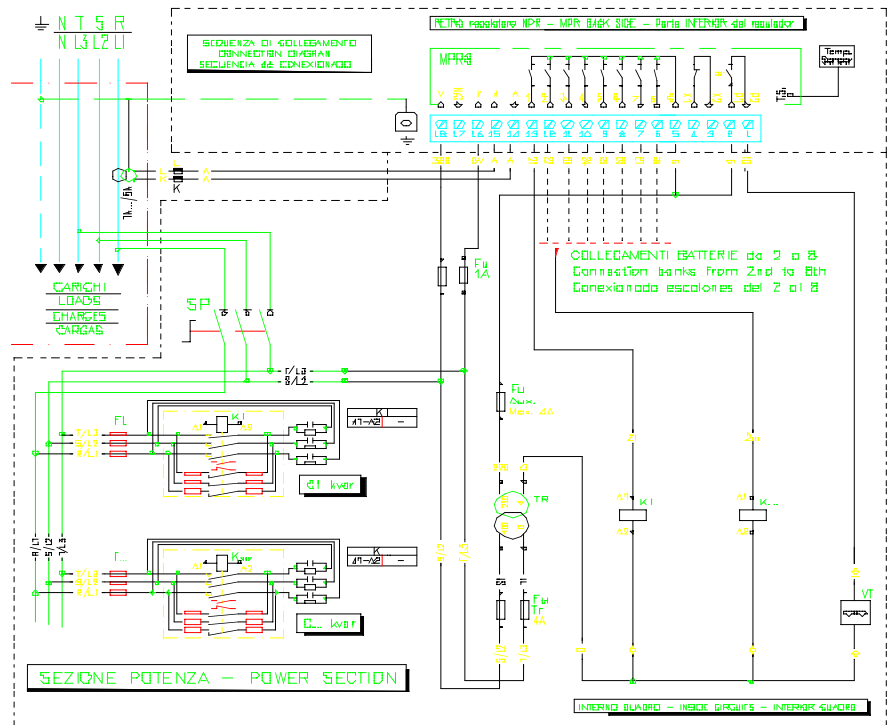

MPR8

Number of terminal	Label of terminal	Description
1	P2	N.O. 5Amps - 250Vac clean contact (resistive load) to be used for control the panel ventilation fans.
2	P1	N.C. 5Amps - 250Vac clean contact (resistive load) to be used for remote alarm signalling. Separate supply required (see chapter 7. ALARMS).
3	X1	Common terminal of relays. To be connected to 220Vac auxiliary transformer. <i>Note: Protect connection with external fuse max. 4Amps.</i>
4	X2	
5	C	
6÷13	8÷1	Connection to contactor coils (from 8 th to 1 st bank).
14	A	Connection to secondary of C.T.
15	A	C.T. = Current Transformer with 5Amps secondary (see chapter 3.)
16	V	Connection to 0Vac - Protect with external fuse.
17	N.C.	Not connected
18	V2	Connection to 380Vac - Protect with external fuse.

3.2 MECHANICAL FIXING: the regulator should be mounted in a cut-out (drilling template 138x138mm.) using the special fixings supplied.

3.3 POWER of CONTROLLED BANKS: the regulator works according to binary logic sequence; the switching on and off of capacitors banks always start from the first bank. For correct operation of the automatic bank, the power ratio per bank should be:

- equal to each other (1-1-1-1-1-1-1-1)
- double of the previous bank (1-2-4-8-16-32)
- equal or double of the previous bank (1-1-2-2-4-4)

3.4 NUMBER of STEPS:

is determined by the power combination which has been used on single capacitors bank:

- Examples:
- 6 banks in the sequence 1-1-1-1-1-1 make 6 steps
 - 6 banks in the sequence 1-1-2-4-4-4 make 16 steps
 - 6 banks in the sequence 1-2-4-8-16-32 make 63 steps

Note. Where the step sequence is uneven too high a number of steps will result in a high number of switching operations, which will considerably reduce the life of the equipment. With the first step too high hunting may occur which again would produce excessive wear and reduced life of the components.



- NORMALLY 8-16 REGULATING STEPS IS THE BEST SOLUTION TO ADOPT

4. WORKING SITUATION

The AUTOMATIC (default condition when switching on the regulator) or MANUAL working condition are obtained by pushing the button .

- **AUTOMATIC** working

This is the standard condition when switching on the regulator. When the network is inductive (motors, transformers, fluorescent lamps, etc.), the red led  is on and the regulator begins to connect capacitor banks.

If too many capacitor banks are connected, the red led  will be on and the regulator will begin to switch off banks. The preset PF value will be achieved when both Led's  and  are off.

- **MANUAL** working

Press button . When the regulator is in the manual mode the red Led on the button will be on. In manual mode, the regulator will not operate without an external control (both inductive and capacitive Led's are off). By pressing either the "+" or "-" buttons all banks will be connected or disconnected one step at a time. Each button must be pressed for at least 25 secs. Operating banks will be shown by the red Led's corresponding to numbers 1 - 2 - 3 When a power loss occurs, all capacitor banks will be switched off automatically. When the power returns, the regulator will again insert all banks step by step.

5. DIGITAL DISPLAY

It is possible to read the values of PF, VOLTAGE, CURRENT and TEMPERATURE μC on the digital display. The current value should be multiplied by the CT ratio to determine the actual load current. The TEMPERATURE reading is as measured at the point of external control by the sensor - MPR8 range only.

Pressing the  button it will cycle around the options. On power up PF is displayed automatically

The - led near the two numbers display is illuminate if the P.F. value is more than 1.00.

6. SETTINGS ON REGULATOR

After making the required connections to the regulator, the following adjustments should be made.

Note: In the presence of alarms, the settings mode is forbidden.

- **C/K setting**

By pressing the  button for 4 secs in MANUAL mode, the "SETTING MODE" will be entered. The

C/K

red led  will illuminate and, at the same time, a number (d.0.1_d.0.5) will appear in the digital



display. To release the  button and use the  or  buttons to change the selection. The suggested value to set is given on the table "C/K VALUES" (see table on the next page). The number will represent the range (positive/negative) of the PF values possible to obtain.

TABLE for medium current values of 2,5 Amps

C/K		C = First bank power expressed in kvar (400V)								
T.A.	K	2,5	5	6	10	12,5	20	25	40	50
30/5	6	0.3	0.5	0.5	-	-	-	-	-	-
50/5	10	0.3	0.3	0.4	0.5	-	-	-	-	-
60/5	12	0.3	0.3	0.4	0.5	0.5	-	-	-	-
80/5	16	0.2	0.3	0.3	0.5	0.5	0.5	-	-	-
100/5	20	0.2	0.3	0.3	0.3	0.4	0.5	0.5	-	-
150/5	30	0.2	0.2	0.3	0.3	0.3	0.5	0.5	0.5	-
200/5	40	0.2	0.2	0.2	0.3	0.3	0.3	0.4	0.5	0.5
250/5	50	0.1	0.2	0.2	0.3	0.3	0.3	0.3	0.5	0.5
300/5	60	0.1	0.2	0.2	0.2	0.3	0.3	0.3	0.4	0.5
400/5	80	0.1	0.2	0.2	0.2	0.2	0.3	0.3	0.3	0.4
500/5	100	0.1	0.1	0.2	0.2	0.2	0.3	0.3	0.3	0.3
600/5	120	0.1	0.1	0.1	0.2	0.2	0.2	0.3	0.3	0.3
800/5	160	0.1	0.1	0.1	0.2	0.2	0.2	0.2	0.3	0.3
1000/5	200	0.1	0.1	0.1	0.1	0.2	0.2	0.2	0.3	0.3
1200/5	240	0.1	0.1	0.1	0.1	0.1	0.2	0.2	0.2	0.3
1500/5	300	0.1	0.1	0.1	0.1	0.1	0.2	0.2	0.2	0.2
2000/5	400	0.1	0.1	0.1	0.1	0.1	0.1	0.2	0.2	0.2
2500/5	500	0.1	0.1	0.1	0.1	0.1	0.1	0.1	0.2	0.2
3000/5	600	0.1	0.1	0.1	0.1	0.1	0.1	0.1	0.2	0.2
4000/5	800	0.1	0.1	0.1	0.1	0.1	0.1	0.1	0.1	0.2
5000/5	1000	0.1	0.1	0.1	0.1	0.1	0.1	0.1	0.1	0.1

When the CT secondary current signal is lower than 2 amps, the C/K value should be increased by 0,1

- When using the regulator on 220/230 Vac networks the C/K values should be doubled.
- - means installation of C.T. with primary value too small.

• **PF setting**

After setting the C/K value, press the button again for 4 secs to indicate the selected PF required. At the same the red led  will illuminate. To release the button and use the or buttons to change the selection. A PF of 0.95 is recommended.

Example: setted C/K = "0.3" setted PF = "0.97"
 The regulator will switch bank to achieve a PF value within 0.94 and 1.00 (0.97 – 0.03)

The - led near the two numbers display is illuminate if the P.F. value is more than 1.00.

6.1 SAVING the SET VALUES

By pressing the button the C/K and P.F. values which have been selected will be saved and the Regulator works in AUTOMATIC condition.

7. ALARMS

The MPR has a normally closed N/C alarm contact (rated 5 A 250 V resistive load). It will be possible to give an external alarm signal. This contact is signed with X1 and X2 (ALARM) in the base of the regulator. When alarm condition disappears, the regulator will reset itself automatically.

- **No Supply voltage alarm**

When the voltage supply is lost, the digital display is off and the alarm contact (X1 and X2) is closed.

- **Low PF value in the network**

If after 15 minutes the preset PF is not achieved, the alarm contact closes and the actual PF is displayed. At the same time the Cos ϕ Led flashes. The contact closes again when the preset conditions are met. The Cos ϕ led however continues to flash until the RESET PROCEDURE is performed.

- **Voltage alarm**

When the supply voltage is higher than 110% of the rated value (for at least 10 secs.), the regulator will switch off, step by step, all capacitors banks. Under such condition the MPR displays the VOLTAGE value, the related VOLT led (V) flash and the N/C alarm contact for the external signal (X1 - X2) will close. The alarm condition will clear when the voltage is again within correct parameters. The "V" Led however will continue to flash in order to show, to the operator, which alarm condition was on. To reset the alarm memory the RESET PROCEDURE should be performed.

WHEN THE VOLTAGE ALARM CONDITION IS ON, ALL MANUAL AND AUTOMATIC OPERATING FUNCTIONS ARE UNAVAILABLE.

- **Current signal alarms**

⇒ **Max current.** It occurs when the current value in the secondary of the CT transformer is higher than 5Amps (for at least 10 secs). In such a condition, the MPR displays the CURRENT value, the related CURRENT Led (A) will flash and the N/C alarm contact (X1 - X2) will close. The alarm fault condition clears when the current returns to rated conditions. The "A" led however will continue to flash in order to show, to the operator, which alarm condition was on. To reset the alarm memory the RESET PROCEDURE should be performed.

⇒ **Min current alarm.** It occurs when the current value in the secondary side of the CT transformer is lower than 500 mAmps (for at least 10 secs). In such a condition, the MPR displays the CURRENT value will flash. When the Min current alarm is operating, the MPR is only able to switch off the capacitor banks if the PF value is more than 1. The alarm fault condition clears when the current returns to rated conditions.

⇒ **Current lower than 10 mAmps.** In this condition the regulator will only operate in MANUAL mode. The numerical display will show the symbols"-.-", and the related CURRENT Led (A) will flash. The N/C alarm contact (X1 - X2) will close. The alarm fault condition clears when the current returns to rated conditions. The "A" Led however will continue to flash in order to show, to the operator, which alarm condition was on. To reset the alarm memory the RESET PROCEDURE should be performed.

- **Temperature alarm (only for MPR8)**

The MPR8 regulator incorporates a temperature control circuit. The temperature sensor must be connected with the regulator switched off.

⇒ **First step (35°C).** Causes the N/O contact (5 A 250 V resistive load) connected to terminal P1 and P2 (VENT) to close. The temperature differential is 5 °C. This contact should be used to control the panel ventilation fans.

⇒ **Second step (50°C)** The regulator will rapidly switch off all capacitors banks. With this alarm condition, the MPR displays the TEMPERATURE value, the related TEMPERATURE Led (°C) will flash and the N/C alarm contact for the external signal (X1 - X2) will close. The alarm fault condition clears when the temperature value falls below 45 °C. The "C" Led however will continue to flash in order to show which alarm condition was on. To reset the alarm memory state the RESET PROCEDURE should be performed.

WITH THE MAXIMUM TEMPERATURE ALARM CONDITION ON, ALL MANUAL AND AUTOMATIC OPERATING FUNCTION ARE HALTED

- **Supply interrupts**

To avoid dangerous operating condition on contactors when the supply voltage is interrupted, the MPR switches off all capacitors banks until reconnection. Micro breaks trouble on network must be solved by the client.

RESET PROCEDURE

It is necessary to select the values corresponding to the flashing Led (alarm memory state condition)

and press the  button.

8. WORKING TROUBLES and SOLUTION

Most malfunctions are caused by incorrect connections. The most common faults are as follow:

TROUBLE	SOLUTION
All banks on with a low inductive load on the network	The CT is connected upstream the load but not of capacitors. Connect the CT as shown in the connection diagram
Continuous switching on and off of first bank (hunting phenomena)	a) The C/K value is not correct. Check in the table "C/K VALUES" for the right value b) The power of the first bank is too high for the selected PF requirements Reduce the first bank power according to paragraphs "BANKS POWER" and "NUMBER OF STEPS" - Increase the selected P.F. value.
Displayed PF values not correct	a) CT installed in the wrong phase: connect to phase L1.
IND and CAP Led s off	a) Possible stand-by condition: at least one capacitor bank on. Check the PF value of the network on the display b) Possible MANUAL working condition: choose the AUTOMATIC operation
IND led ON and no insertion of capacitor banks	a) Minimum current alarm. Current lower than 500mA (see chapter 7. ALARMS).
CAP led is ON without capacitor banks working	a) Zero current signal: check the C.T. and its connection and ensure the minimum secondary current level is least 10mAmps. b) C.T. connected on the supply cable of the PFC equipment. Connect according to electrical scheme at page 11. c) C.T. installed in the wrong phase: connect to phase L1.
Blinking display	a) Alarm condition of least one value: see chapter 7. ALARMS. b) Check supply voltage is correct.
Display off, regulator not working	a) Check if supply voltage is present. b) Check if supply voltage is equal to the rated voltage of the regulator.
Display on, banks inserted signalling, but capacitors not working	a) Check if supply voltage is equal to the rated voltage of the regulator. b) Check the 0 connection on contactors. c) Check if 220V has been connected on "C" terminal. d) Check contactor functioning.
Displayed CAP on display	a) Possible capacitive load condition. b) CT installed in the wrong phase: connect to phase L1. c) P.F. lowers than 0,15 IND or CAP.
Displayed EEE on display	Minimum current alarm or zero current signal
Led of displayed measure is blinking	ALARM MEMORY (see alarm paragraph).

IF PROBLEMS PERSIST AFTER ALL ABOVE MENTIONED SOLUTIONS SWITCH OFF THE REGULATOR FOR AT LEAST 20 SECS AND THEN SWITCH ON AGAIN.

IF THE PROBLEM IS STILL PRESENT PLEASE CALL OUR TECHNICAL DEPARTMENT.

9. TECHNICAL DATA

Rated supply voltage	Multivoltage 380÷415V a.c. – 10% (230-440 Vac on request) 400V -10% / +5% continuous operation
Rated consumption	10 VA
Rated supply current	By means of C.T. secondary side 5Amps max., 1 st class - 5VA (Imin.=500mA)
Current circuit consumption	2VA
Rated frequency	50Hz (60Hz on request)
Controlled banks	6 (MPR6) - 8 (MPR8)
Output relays	5 Amps 250 V a.c. resistive loads
Max current on relays common circuit	5Amps at 40°C resistive load
Switching steps delay	25" (5" or 1" on request)
Alarm delay	10"– 1"
P.F. setting	0,90 IND ÷ 0,90 CAP
Operating range	Power Factor 0,20÷1,00 IND / CAP
Digital display	Three numbers display
Measurement monitoring	Power Factor 0,20÷1,00 IND. / CAP. accuracy – 1% full scale Voltage measurement 360÷440Va.c. accuracy – 2% full scale Current measurement 0,5÷5Amps accuracy – 2% full scale Temperature measurement 10÷70°C accuracy – 10% full scale
Display accuracy	– 2 digits
Connection	By means of plug connector with terminal fixing screws, for the cable have to be of 2,5 mm ² section max.
Mechanical dimensions	144x144 mm FRONT (according to DIN43700) - 85mm thickness
Cut out dimension	138x138 mm (tolerance -0mm /+ 1mm).
Plastic case	Insulating self-extinguishing material
Weight	1,2 Kg
Protection degree (CEI-EN 605.29)	IP 54 front panel - IP20 rear panel
Working temperature	-5°C / + 50°C
Storage temperature	-10°C / +50°C
Relative humidity	Max. 90% at 20°C non-condensing
Altitude max.	2000 meters
Indoor service	

10. WARRANTY, INSTRUCTIONS and LIABILITY

WARRANTY

Comar Condensatori S.p.A. guarantees its own products for twelve months from purchase date. The warranty covers the faults of materials and manufacture and it has to be understood for goods ex-works. Before the equipment works, all instructions, present on this handbook, have to be meticulously followed. Breakdowns caused from improper use and/or not conformity to enclosed instructions and faults caused from tampering by unqualified technicians aren't covered.

The misuse of any of the previous points will erode the right of warranty.

GENERAL INSTRUCTION

- Read the instructions in this handbook because they provide important indications about the safety of installation, use and maintenance of installation. Take carefully this handbook for any information.
- Check the integrity of the equipment after unpacking it.

In case of doubt, don't use the P.F. Corrector and ask for skilled staff.

Note: If the equipment has fallen or has been violently or shaken during shipping, it could suffer internal

damage, which may be dangerous.

- Before connect the equipment, check the data card: this has to be in conformity with the power electric network (the plate is located on the back of the P.F. Regulator).
- This equipment will be assigned only to the use for which it has been specifically made.

Each other use has to be considered improper and therefore dangerous.

- In order for the correct functioning of the equipment the limits of voltage, current and temperature, imposed by the CEI and IEC standards, must never be exceeded.
- The equipment has to be protected from atmospheric conditions.

No type of tampering is permitted on the electronic circuits of P.F. Regulator.

- Possible interventions will be performed by COMAR staff.

LIABILITY

Comar Condensatori S.p.A. are not liable for direct or indirect damages consequent the missing or the incorrect operation.

In any case and for any reason COMAR Condensatori S.p.A. can not be considered liable for possible direct or indirect damages, consequent the malfunctioning of P.F. Corrector, caused from mistakes of assembly or from inadequate use of the same.

The manufacturer reserves the right to modify data and sizes without previous notice.