



OVERVIEW

Please read this handbook careful: it provides important information about safety, usage and maintenance of our product.

The BMR electronic regulator allows the control of the power factor (cosφ) on electric networks by measuring all the electrical values such as Voltage, Current, THDI(%),etc...

Using accurate diagnosis software, the regulator measures only the fundamental values by removing the harmonics components.

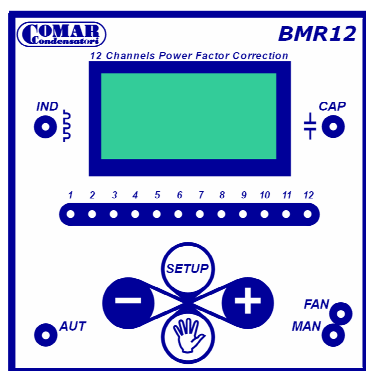

A large LCD display allows all the data to be easily read. Regulator operation is indicated by the LEDs on the front panel. All the user operations can be performed using the four button keypad.

INSTALLATION

Mounting the regulator in a cut-out panel (138x138mm) by behind panel clamps.

The regulator is only suitable for an electrical network with a frequency of 50/60Hz through a Current Transformer placed on the phase L1 and connected between the K-L terminals.

The C.T. must measure all the currents (inductive and capacitive) to ensure correct operation.

Voltage references must be connected to lines L2-L3 and the regulator power supply on terminals <S1>-<S2>; for voltage supplies provide a fused supply in accordance with your technical standards. Connect the aux voltage to terminal <C>, which is common to the NO relay outputs, and connect the outputs 1 to 12 to control the banks of capacitors.

A volt-free contact on leads <C1>-<C2> is available to remote monitoring an alarm status or to control a cooling/fan system: for fan control, connect the included temperature probe on <P1>-<P2> leads.

Be sure to know the harmonics characteristic of the network that must be compensated, then ensure the P.F.C. equipment or capacitors you are using are suitable for the network characteristics and, if necessary to avoid any safety problem on your equipment, adjust the THERM THDI% and OVER THDI% parameters.

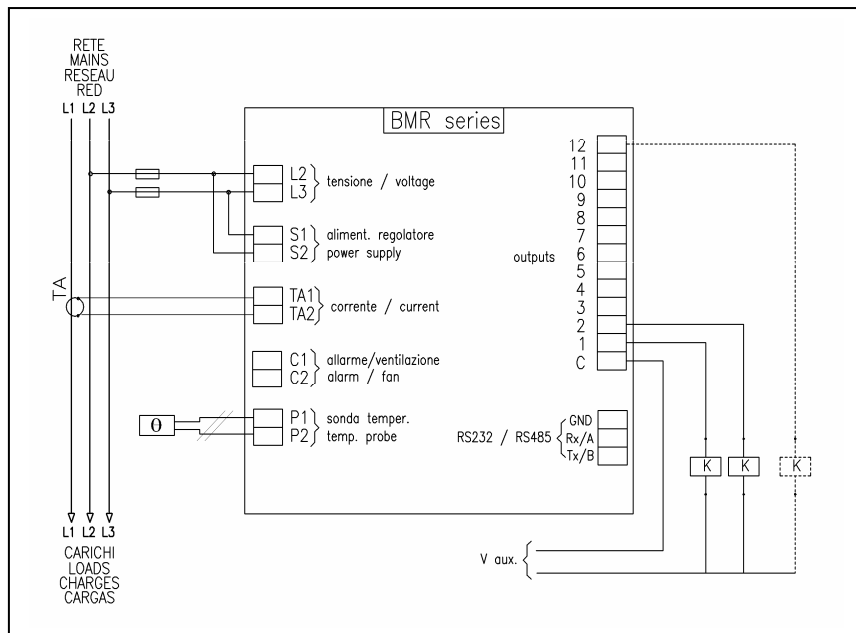

PROGRAMMING

The parameters can be set by two menus: a base menu (“PAR SETUP”) and advanced (“MAIN SETUP”).

To navigate between the setting paramaters press the **SETUP** button; press **- DOWN** or **+ UP** button to modify each paramater.

In the first menu (“PAR SETUP”) the parameters to set are the minimum installation required and are shown below:
 PAR TA→SENS→OVER Temperature→THERM THD I%→
 →OVER THD I%→SENS THD I→SENS DOWN.

- To access the basic (“PAR SETUP”) menu:
- ❖ set the regulator on MANUAL mode by pressing the **MAN/AUT** button and disconnect all the banks (**I**)
- ❖ press and hold the **SETUP** button until to read “PAR SETUP” onto digital display.

- PAR SETUP parameters description:
- PAR TA =>** Current Transformer ratio (eg. 1000/5).
 - SENS =>** tolerance sensibility to the cosφ regulation.
 - OVER TEMP =>** maximum operating temperature (°C).
 - THERM THD I% =>** THD(I)% alarm value (see also the SENS THD I% parameter).
 - OVER THD I% =>** instantaneous THD(I)% peak alarm value.
 - SENS THD I% =>** THD(I)% alarm value time (sec.).
 - SENS DOWN =>** alarm reset time delay :

- if set to ON, resume instantaneously the normal operations when the alarm ends;
- if set to OFF, resume the normal operations with a delay time equals to the SENS THD I% value;

To modify these parameters, press and hold the **SETUP** button and change using the **UP** or **DOWN** buttons.

(1): To switch between AUTOMATIC and MANUAL mode, press the **MAN/AUT** button for 5 secs.

To switch ON or OFF a bank manually, press **MAN/AUT** for 5 secs. (the AUT led turns off and the MAN led lights), press **UP** or **DOWN** to select the capacitors bank desired then confirm with **SETUP** button. To verify the status of the bank selected, the power (in kvar) appears on the display.

In the menu advanced (“MAIN SETUP”) you configure the compensation equipment parameters like: kvar power banks, capacitors rating voltage, switching delay, network rating frequency, type of network (single or 3-phase), alarm mode relays (NC or NO).

To enter in the MAIN SETUP:

- ❖ set the regulator on MANUAL mode (you should read the PF on the display);
- ❖ disconnect all the banks, press and hold the **SETUP** button until to read PAR SETUP onto digital display: press and hold again **SETUP** until “MAIN SETUP” is displayed.

MAIN SETUP parameters description:

POWER CAP n° => reactive power ratio (kvar) of each bank; to set a bank in **FIX** mode (*always connected*) set the power to “0,0” and press **DOWN** to read “**FIX**” on the display.

CAP VOLTAGE => voltage ratio (V) of the capacitors banks

CAP RC TIME => switch delay time (sec.)

----- CAUTION -----

Contact the capacitors manufacturer before modify this value.

ALARM RELAY => type of output contact relay (NC, NO or FAN mode) in alarm condition.

EXTERNAL TV => set the Voltage Transformer (primary and secondary value) if used.

LINE FREQ => network rating frequency (50 or 60Hz).

LINE TYPE => network system (single or 3-phase).

SYSTEM MODE => measurement on 2 or 4 quadrants.

USER INTERFACE OPERATION

After the setting procedure, the PF ($\cos\phi$), the voltage and the current measured appears on the display: you can read the reactive power needed to obtain the target $\cos\phi$ chosen. In AUTOMATIC mode, pressing the **SETUP** button you can navigate between the pages in the sequence below :

MAIN → **THD** → **FAN** → **SETcosφ** → **POWER** → **MAX(line)** → **MAX(power)**

MAIN => network parameters measurements including : $\cos\phi$, true RMS voltage, true RMS current, Delta Power (means the reactive power gap to target the SET $\cos\phi$)

THD => total THD% current value, fundamental current and harmonic current value measurement

FAN => real time temperature measured by the probe (if connected) in °C

SET cosφ => target P.F. ($\cos\phi$): in AUTOMATIC mode you can just check it, in MANUAL mode you can set the value by **UP** and **DOWN** buttons

POWER => Active and Reactive Power measurements

MAX(line) => max values of network parameter measured (2)

MAX(power) => max network energy values measured (2)

Note: if the **POWER FACTOR** value on the display is not stable, reverse the K-L (C.T. signal) connections.

(2): All the history measurements can be reset by pressing the **UP** and **DOWN** buttons at same time.

The display of the parameter is 30sec., after this time the regulator come back to the main display page.

During the manual control of the banks, the AUTOMATIC control is inhibited but the others control are operating (measurements and alarms). Moreover, if the voltage supply is interrupted, the bank status set in MANUAL mode is stored in a non-volatile memory: when the voltage supply is restored, the regulator switches in the memorised banks.

ALARMS: The output relay <C1>-<C2> (see settings of the ALARM RELAY contact), switches when any of following conditions occur:

HIGH VOLTAGE: the voltage measured to the <L2>-<L3> terminals exceeds the 110%Un for 15 min.; the alarm relay operates in the programmed mode.

LOW VOLTAGE: the voltage supply is less than 85%Un; and the alarm relay operates in the programmed mode.

HIGH CURRENT: the current measured from the C.T. exceeds the 110% In. the alarm relay operates in the programmed mode.

LOW CURRENT: the current measured from the C.T. is less than 6%In for 5secs.: if this conditions during more than 2 min. the regulator switch OFF all the capacitors banks, and the alarm relay operates in the programmed mode.

UNDER COMPENS: this alarm appears when the PFC equipment does not reach the target $\cos\phi$ for 15min; and the alarm relay operates in the programmed mode.

OVER COMPENS: this alarm appears when the $\cos\phi$ is Capacitive for 2 min; the regulator switches OFF all the capacitors banks and the alarm relay operates in the programmed mode.

HIGH THD%: the harmonic distortion value is more than the THERM THD% value set on the PAR SETUP menu; the regulator switches OFF all the banks and the alarm relay operates in the programmed mode.

OVER THD%: the harmonic distortion value is over the instantaneous OVER THD% value set on the PAR SETUP menu; the regulator switches OFF all the banks and the alarm relay operates in the programmed mode.

OVER TEMPERATURE: the temperature measured by the probe (if connected) is over the value set in the PAR SETUP menu the regulator switches OFF all the banks and the alarm relay operates in the programmed mode.

The normal functions resume when the alarm condition ends and the alarm relay is reset.

TECHNICAL DATA

Operating voltage:	380-415 V c.a. + - 10%
Operating frequency:	50/60 Hz
Consumption:	5VA
Voltage input:	-40% - + 15% della Vn
Current input:	2.5 – 110% Ie
Power Factor range:	0.85 Ind a 0.95 Cap
Measures:	Voltage, Current, Cosφ, THDI%, Inductive, Reactive and
LCD Display:	16 characters 4 rows backlight
Led:	Relay step; MAN/AUT mode; IND/CAP; FAN
Switching banks relay:	8 (DPx8x) – 12 (DPx12x)
Alarm output relay:	1 (programmable)
Output contacts rating:	8A 250V (AC1), max switching 440V
Interface connector:	Standard
Operating temperature:	-20°C + 55°C
External degree protection:	IP41 ; optional IP54-IP65
Communication protocol:	MODBUS RTU – RS232 or RS485

MAIN FEATURES

- ABS enclosure 144x144mm
- Voltage supply 380V-415V (on request 230V)
- Measuring input voltage max 525Vac
- Measuring input current by C.T. xx /5A
- Main current setting range 5A to 10000A
- Voltage/current true RMS measurement
- Current THD% distortion up to 32° harmonic
- Power factor measurement (cosφ)
- Measurement system based on 2 of 4 quadrants
- External voltage transformer settings
- Start ventilation temperature setting (FAN)
- Max. operating temperature for Alarm (OVERTEMP)
- Power factor setting range 0.85 Ind to 0.95 Cap
- Single step reactive power setting (kvar) 0.1 to 6000
- Switching time between steps 5 to 240s (default 30)
- Rating voltage capacitors setting 80 to 650V
- Cosφ visualization on fundamental voltage/current measure
- Sensibility on delay time range set
- Max. Continuous THDI set value (THERM THDI%)
- Max. Instantaneous THDI set value (OVER THERM THDI%)
- THDI% sensibility time delay setting
- Measurements:
 - True RMS line current and voltage
 - Fundamental current value
 - Harmonic current
 - Power factor based on RMS values
 - Current THDI% value
 - Operating temperature in °C (by probe)
 - Max. current/voltage measured
 - Active, reactive and Apparent Power
 - Difference between the operating reactive power and his setting
 - Weekly power factor value (medium)
 - Active/reactive power measured on 4 quadrants

WARRANTY

Comar Condensatori s.p.a. guarantees its products for 12 months from purchase date.

Technical specifications are valid under normal operating conditions as specified in this document. We do not accept any responsibility for any misuse of the product and cannot be held liable for indirect or consequential damages.

IMPORTANT:

Be sure to know the harmonics characteristic of the network that must be compensated, then ensure the P.F.C. equipment or capacitors you are using are suitable for the network characteristics.

REFERENCES

CEE 73/23 e 93/68 (bassa tensione - low voltage)
CEE 89/336 e 93/68 (EMC)
EN 61000-6-1 – EN 61000-6-2
EN 61000-6-3 – EN 61000-6-4
EN 60335-1